



Öhlins Front Fork Kit for
Motocross and Enduro

Owner's Manual - General Mounting Instructions

Safety Precautions

Note!

The front fork is a very important part of the vehicle and will therefore affect the stability.

 *Read and make sure that you understand the information in this manual and the mounting instructions before you use this product. If you have any questions regarding installation or maintenance please contact your Öhlins dealer.*

 *Öhlins Racing AB can not be held responsible for any damage to the front fork, vehicle, other property or injury to persons, if the instructions for installing and maintenance are not followed exactly.*

Warning!

This product was developed and designed exclusively for a specific vehicle model and should only be installed on the intended vehicle model in its original condition as delivered from the vehicle manufacturer.

 *This product contains pressurized nitrogen gas (N₂). Do not open, service or modify this product without proper education (authorized Öhlins dealer/distributor) and proper tools.*

 *After installing this product, take a test ride at low speed to make sure that your vehicle has maintained its stability.*

 *If the suspension makes an abnormal noise, or the function is irregular, or if you notice any leakage from the product, please stop the vehicle immediately and return the product to an Öhlins Service Centre.*

Note!

When working on this product, always consult your Vehicle Service Manual.

 *This Manual should be considered as a part of the product and should therefore accompany the product throughout its life cycle.*

Safety Symbols

In this manual, mounting instructions and other technical documents, important information concerning safety is distinguished by the following symbols:



The Safety Alert Symbol means: Warning! Your safety is involved.

Warning!

The Warning Symbol means: Failure to follow warning instructions can result in severe or fatal injury to anyone working with, inspecting or using the front fork, or to bystanders.

Caution!

The Caution Symbol means: Special precautions must be taken to avoid damage to the front fork.

Note!

The Note Symbol indicates information that is important regarding procedures.

	Page
Safety Precautions	1
Contents	2
Recommended Tools	2
How to Install	3
Replace Spring	6
Set-up	7
Measure Spring Preload	8
Adjustments	9
Oil Volume - Force Diagram	9
Spring Guide	10
Inspection and Maintenance	10

Note!

To install the Cartridge Kit on your motorcycle you will also need the Application Specific Mounting Instructions. Contact an Öhlins dealer for advice.

Recommended Tools

OEM Fork Cap Tool *
Öhlins Fork Cap Tool octagon 50 mm
Socket for OEM Base Plug *
Socket for Öhlins Base Plug *
Socket 12 mm for Öhlins Shaft End
Pliers (for security snapping)
Tool 01890-01 Plug

* See *Application Specific Mounting Instructions*

How to Install

Remove the fork legs from the vehicle

⚠ Warning!

It is advisable to have an Öhlins dealer install the front fork kit.

When installing, consult your Vehicle Service Manual.

1

Put the motorcycle on a workstand so that the front wheel barely touches the ground.

⚠ Warning!

Make sure the vehicle is securely supported so that it will not tip.

2

Remove the front wheel and the brake caliper.

3

Measure the distance from the top of the fork leg to the top of the upper triple clamp according to figure.

👁 Note!

Note this dimension as fork height position.

4

Loosen the upper triple clamp by loosening the screws.

5

Loosen (but do not remove) the top cap 1/2 turn. Use the OEM Fork Cap tool from the motorcycle manufacturer.

6

Loosen the lower triple clamp by loosening the screws.

7

Remove the front fork legs from the motorcycle.

8

Clean the fork legs thoroughly. Make sure to clean underneath the fork bottoms.

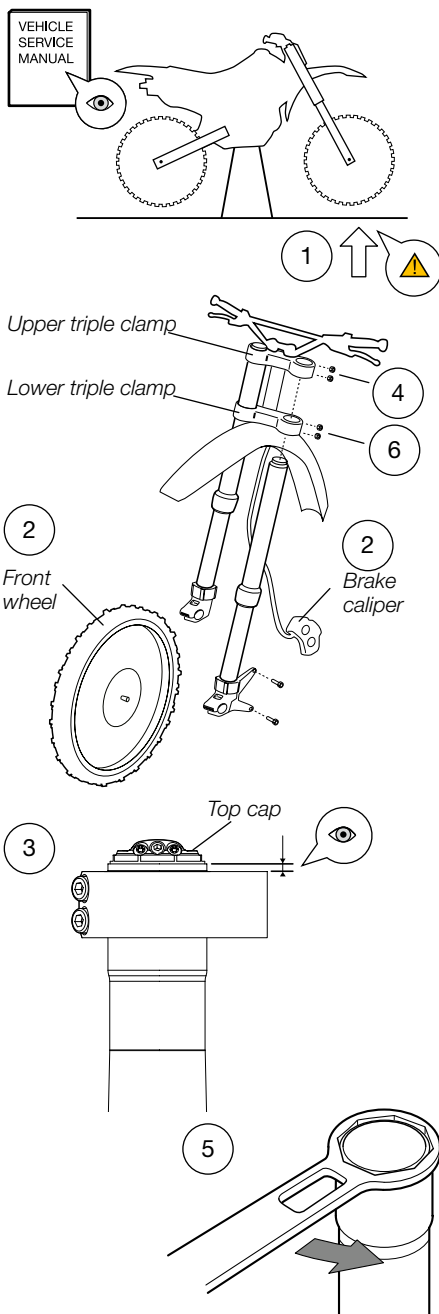

Disassemble the original front fork

9

Follow your vehicle service manual to remove the original front fork kit and spring from the fork leg. Turn the fork leg upside down to pour out the oil.

Install the Öhlins front fork kit

👁 **Note!**

On some brands/models step 10 shall not be performed. See Application Specific Mounting Instructions for information.

10

Install the hydraulic stop cup from the upper end of the fork tube. Clean contact surfaces between the hydraulic stop cup and fork bottom with contact cleaner.

👉 **Caution!**

Make sure that the hydraulic stop cup is well seated before tightening.

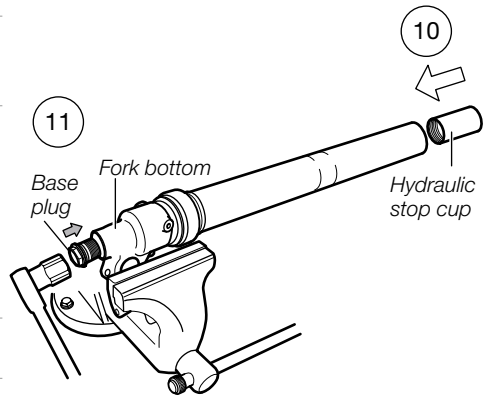

11

Install and tighten the base plug into the fork bottom.

Tightening torque 45 Nm

👉 **Caution!**

If the hydraulic stop cup is turning, carefully use an impact machine.

12

Install spring support washer (if applicable, see Application Specific Instruction Sheet). Install optional preload washer(s) (optional - see **Set-up data**, *Spring preload*), the recommended Öhlins spring (see **Spring guide**) and the cartridge kit into the standard fork leg.

👁 **Note!**

The preload washers must be below the spring, at the bottom end of the fork leg.

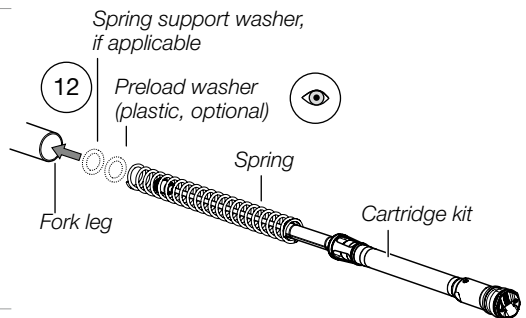

How to Install

13

Tighten the cartridge shaft end into the base plug by turning counter clockwise.

Use a 12 mm socket

Tightening torque 18 Nm - Do not overtighten.

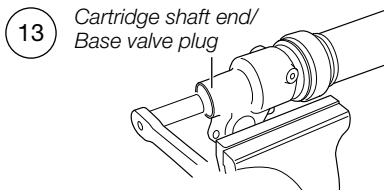

14

Install the security snap-ring at the shaft end groove according to figure.

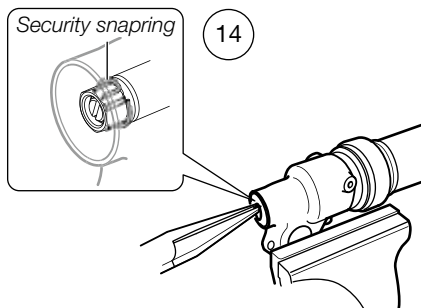

15

Pour Öhlins Front Fork Fluid in the fork leg according to the recommended settings.

16

Tighten the Öhlins fork top cap gently. Use the 50 mm octagon Fork Cap Tool.

Tightening torque maximum 10 Nm.

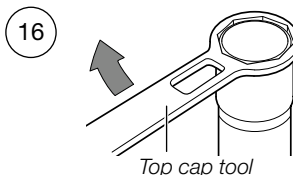

17

Check and set the rebound and compression valves click positions according to the recommended settings in Set-up data in the Application Specific Instruction Sheet.

18

Install the front fork legs into the triple clamps. Use, to begin with, the same height position as before. Tightening torque - see your Vehicle Service Manual.

Reinstall the brake caliper and front wheel.

Make sure that all removed parts are reinstalled as they were before the installation of the Öhlins Front Fork Kit.

Note!

It is very important that the triple clamps are tightened to the correct torque. See your Vehicle Service Manual.

Replace Spring (only)

1
Follow steps 1-8 in chapter *Remove the fork legs from the vehicle*.

2
Unthread top cap from the outer tube.

3
Remove the security snapping in the bottom of the fork with a pair of pliers. Loosen the bottom end of the cartridge kit by turning clockwise.

4
Install the tool 01890-01 (oil plug) by pushing it into the fork bottom. The plug will keep the oil in the fork while changing the spring.

5
Remove the cartridge kit from the fork leg and change the spring. Note the plastic preload washer(s) and spring support washer (if any).

Note!

The preload washers must be below the spring, at the bottom end of the fork leg.

6
Install the cartridge kit into the fork leg and push out the oil plug tool 01890-01.

7
Tighten the shaft end (counter clockwise) into the fork bottom. Tightening torque 18 Nm.

8
Install the security snapping.

Note!

When removing spring and cartridge kit there will be a loss of front fork fluid. Therefore, we recommend adding 15 ml Öhlins Front Fork fluid into each fork leg.

9
Tighten the Öhlins fork top cap gently. Use the 50 mm octagon Fork Cap Tool. Tightening torque maximum 10 Nm.

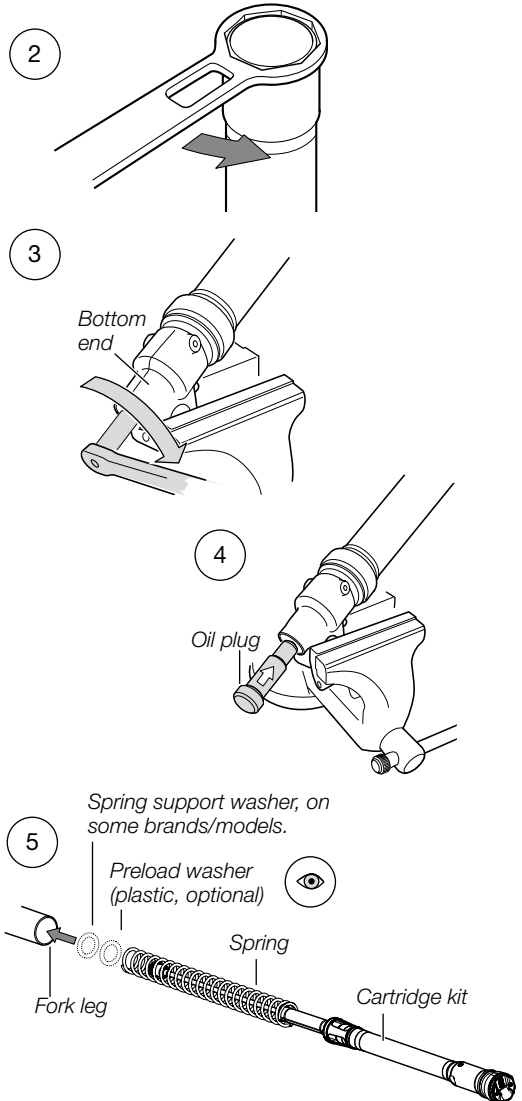

10
Install the front fork legs into the triple clamps. Use, to begin with, the same height position as before. Tightening torque - see your Vehicle Service Manual. Reinstall the brake caliper and front wheel - make sure that all removed parts are reinstalled as they were before the installation of the Öhlins Kit.

Set-up

⚠ Warning!

Before riding, always ensure that the basic settings made by Öhlins are intact. Take notes, adjust in small steps and make only one adjustment at a time.

Step 1

Check Sag and Ride Height

👁 Note!

The following procedure should be performed on a flat surface.

1. Put the motorcycle on a workstand so that both wheels are off the ground and the suspension is unloaded.
2. Mark, for example with a piece of tape, a point immediately above the rear wheel axle.
3. Measure the distance from the marked point to a fixed point, for example the wheel axle. (See figure below: R1)
4. Measure the distance from the bottom of the upper triple clamp to a fixed point, for example the front wheel axle. (F1)
5. Put the motorcycle on the ground so that the front and the rear suspensions are slightly compressed. Repeat the measuring procedures. (R2 and F2)
6. Sit on the motorcycle in normal riding position, properly outfitted in your riding gear. Repeat the measuring procedures. (R3 and F3)

Recommended Measures

If no other recommendations are given in the Vehicle Manual follow the measures below:

Free sag (R1-R2)

Rear 30 - 45 mm

Ride height (R1-R3), (F1-F3)

Rear 100 - 115 mm

Front 40 - 50 mm

Step 2

Adjust spring preload

1. If your measurements differ significantly from the recommendations from the table above, adjust the spring preload. (See section Spring Preload in this manual).
2. If the ride height still differs from the recommendations, you may need to change spring. Contact your Öhlins dealer for advise.

⚠ Warning!

Incorrect spring rate may produce a fork angle that is too steep or too flat. This in turn will give a tendency for over- or understeering, which could seriously affect the handling characteristics of the motorcycle.

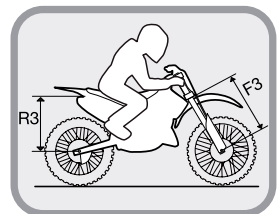
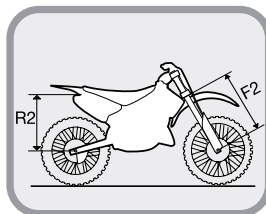
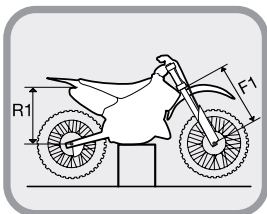

Measure Spring Preload

Five Steps to measure and adjust spring preload;

1. Measure A. Fork outer tube should be slid down to stop and cartridge pulled out to distinct stop (requires a force of about 30 kg).
2. Measure B.
3. Measure C.
4. Calculate preload: $\text{Preload} = B - A - C$
5. Adjust preload according to the desired value according to set-up data, by adding/removing preload washers below the spring.

For recommended Spring Preload, see Application Specific Mounting Instructions.

Fork springs may differ in length. Therefore we recommend you to check the preload on each fork leg and, if necessary, install preload washers to get the correct value. A negative preload of up to minus 2 mm is possible, since the top-out spring still gives a small compression on the main spring.

Preload less than -2 mm will make the fork spring loose when the front wheel is off the ground, which increases wear inside the fork.

Caution!

Preload washers must be placed below the spring, otherwise they will restrict oil flow and the fork may break.

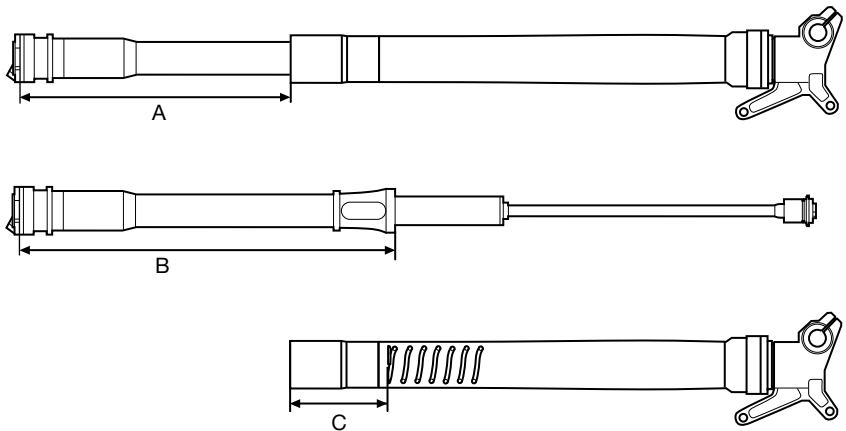

Adjustments

Compression damping adjuster

The compression adjuster is located at the top of the fork leg. Adjust by turning the screw with a 3 mm allen key.

Rebound damping adjuster

The rebound adjuster is located at the bottom of the fork leg. Adjust by turning the screw with a 3 mm allen key.

To Reset

The adjusters have a normal right hand thread. Turn the damping adjusters gently clockwise to fully closed (pos. zero [0]). To open, turn counter clockwise, and count the clicks until you reach the recommended number. For recommended clicks see Set-up data. Static sag can only be changed with softer or harder spring rate.

Caution!

Do not use too much force, delicate sealing surfaces can be damaged.

Note!

The total stroke of the front fork may differ from the original stroke, so that more or less of the steel tube will be visible when the fork is fully compressed.

Compression damping adjuster

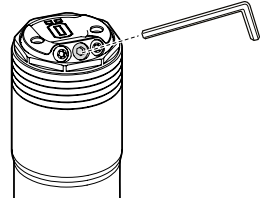

Rebound damping adjuster

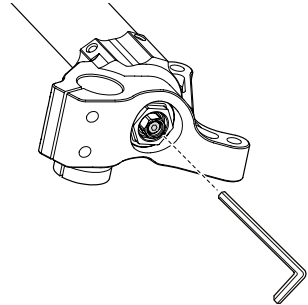
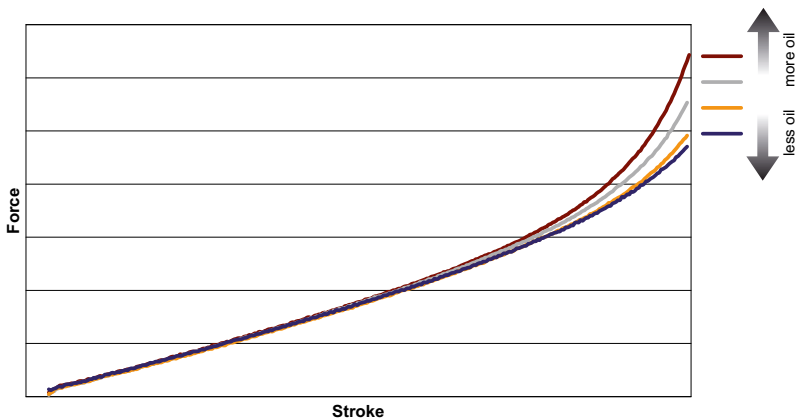

Diagram: Oil Volume - Force



Spring Guide	Rider's weight*	Spring rate
	kg/pounds	N/mm
Motocross/Enduro 250	70/154	4,1-4,4
	75/165	4,3-4,5
	80/176	4,5-4,8
	85/187	4,6-4,9
	90/198	4,7-5,0
	95/209	4,8-5,1
Motocross/Enduro 450	70/154	4,3-4,6
	75/165	4,4-4,7
	80/176	4,5-4,8
	85/187	4,6-4,9
	90/198	4,7-5,0
	95/209	4,8-5,1

* Rider's weight: Rider wearing all riding equipment

Inspection and Maintenance

Preventive maintenance and regular inspection reduces the risk of functional disturbance.

Breather plug

Make sure to aerate the front fork at regular intervals:

1. Put the motorcycle on a workstand so that the front wheel barely touches the ground.
2. Loosen the breather plug to release excessive pressure in the front fork.

Recommended Service Intervals

Every 25 hours. Make your service and maintenance according to Öhlins Workshop manual.

Disposal

Discarded Öhlins products should be handed over to an authorized Öhlins workshop or distributor for proper disposal.

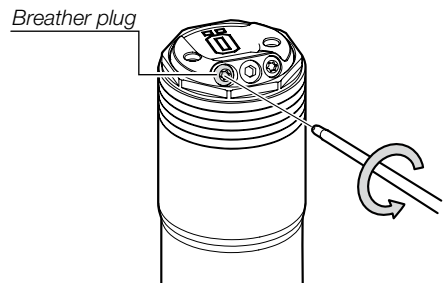



Your Öhlins retailer:

Öhlins Racing AB
Box 722
SE-194 27, Upplands Väsby
Sweden

Phone: +46 (0)8 590 025 00
Fax: +46 (0)8 590 025 80
www.ohlins.com

